

Jandy® Stealth™ Series Pump Tailpiece Replacement Kit Instructions

FOR YOUR SAFETY: This product must be installed and serviced by a professional service technician, qualified in pool/spa installation. The procedures in this manual must be followed exactly. Improper installation and/or operation can create mechanical or electrical hazards which could result in death, serious injury or property damage. Improper installation and/or operation will void the warranty.

These instructions are to be used with the following Jandy Replacement Kits:
R0446101-- 2" X 2.5" Tailpiece Replacement Kit (SHPF/SHPM/JEP)
R0446102-- 2.5" X 3" Tailpiece Replacement Kit (SHPF/SHPM/SWF)
R0446400-- Tailpiece O-ring Replacement Kit (SHPF/SHPM/JEP/SWF)

⚠ WARNING

Before servicing the pump, be sure to switch off the circuit breaker to the circuit supplying power to the pump motor. Failure to do so could result in property damage, severe injury, or death.

| Parts List | R0446101 | R0446102 | R0446400 |
|---------------------|----------|----------|----------|
| Description | | | |
| 2" X 2.5" Tailpiece | 2 | -- | -- |
| 2.5" X 3" Tailpiece | -- | 2 | -- |
| Union Nut | 2 | 2 | -- |
| Tailpiece O-ring | 2 | 2 | 2 |
| Instructions | 1 | 1 | 1 |

1. Introduction

This procedure contains information for the proper replacement of the tailpieces, tailpiece o-rings and union nuts on Jandy Stealth Pumps (SHPF/SHPM), Jandy ePump™ (JEP) and Jandy Stealth WaterFall Pumps (SWF).

Refer to Figure 1 and the parts list to identify part(s) included in each replacement kit. **These instructions must be followed exactly. Read through the instructions completely before starting the procedure.**

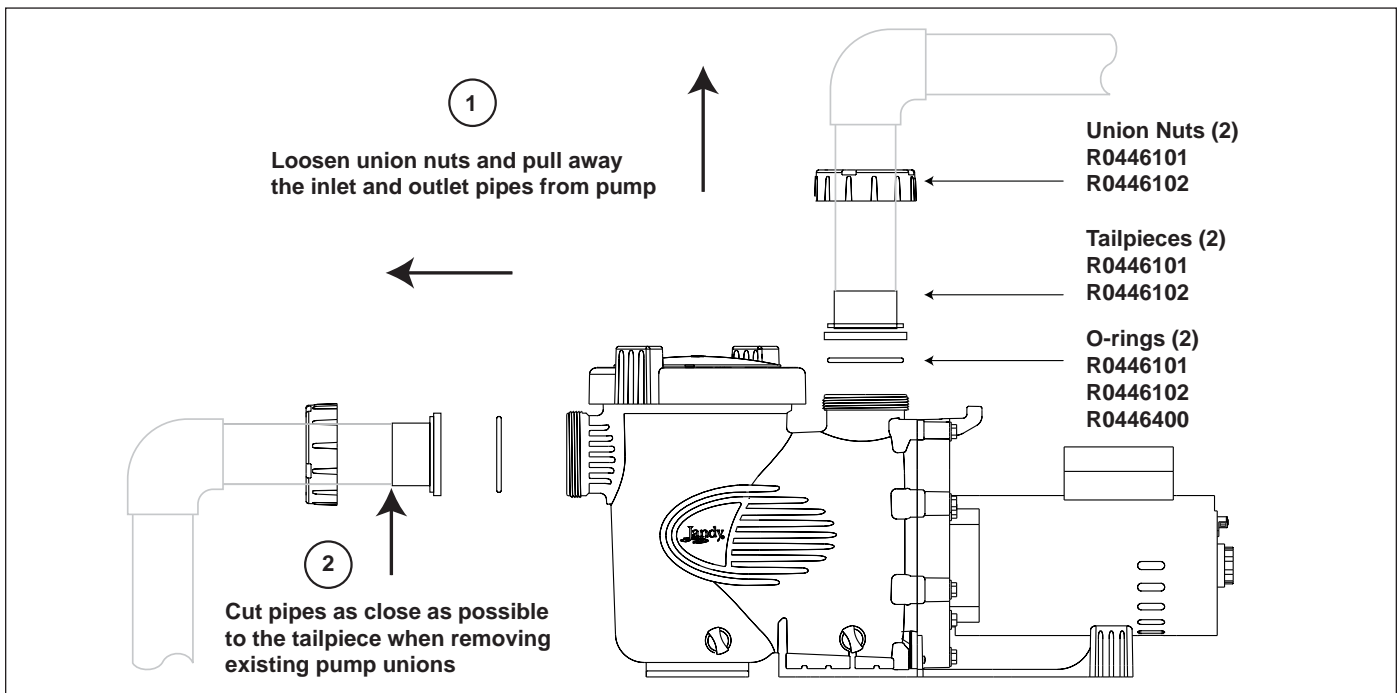

H0576800A

Figure 1. Replacement and Fitting of the Inlet and Outlet Tailpiece

2. Removal of the Tailpiece

- 2.1 Turn off the pump. Switch off the circuit breaker to the pump motor.
- 2.2 Close all necessary valves to prevent pool water from reaching the pump. Remove the drain plugs and o-rings to drain the water from the pump.

WARNING

Due to the potential risk of fire, electric shock, or injuries to persons, Jandy Pumps must be installed in accordance with the National Electrical Code (NEC), in the USA, or the Canadian Electrical Code (CEC) in Canada. All applicable local codes must also be followed.

The NEC may be obtained by contacting the National Fire Protection Association (NFPA) at 1-800-344-3555 or 1-617-770-3000.

- 2.3 Loosen the union nuts on the inlet and outlet ports of pump body. Pull away the plumbing from the pump. A spanner wrench can be used to aid loosening the union nuts from the ports of pump.
- 2.4 Remove the tailpiece o-rings.

NOTE If you are **ONLY** replacing the tailpiece o-rings (Kit R0446400) continue with step 4.

- 2.5 Remove the tailpieces from the pipes as follows:
 - a. As shown in Figure 1, cut the inlet and outlet pipes as close as possible to the existing tailpieces.
 - b. Discard the tailpieces and union nuts removed from the plumbing.

NOTE These kits do not include couplers or fittings that may be needed for replumbing.

3. Replacement of the Tailpiece

- 3.1 Slip the new union nut onto the pipes with the open threaded end of the nut facing the pump.
- 3.2 Prepare the end of the pipe with the proper PVC/CPVC primer and glue. Make sure to follow the primer and glue manufacturer's instructions for the preparation procedures and curing times.
- 3.3 Depending on the tailpiece size being installed continue with the corresponding step as required.

3.4 For 2" X 2.5" Tailpiece Replacement Only (Kit R0446101):

- a. For 2" pipe size, attach the slip fit side of the tailpiece to the end of the 2" pipe as shown in Figure 2.
- b. Allow the glue to cure completely and then continue with step 4.

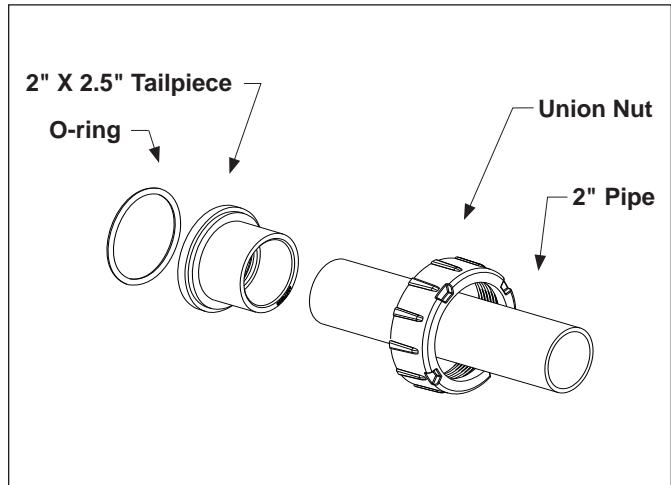

Figure 2. 2" X 2.5" Assembly Shown Connecting a 2" Schedule 40 Pipe

- c. For 2.5" pipe size, attach a 2.5" coupler (not included in the kit) onto the tailpiece. Attach the end of the 2.5" pipe to the other end of the coupler as shown in Figure 3.
- d. Allow the glue to cure completely and then continue with step 4.

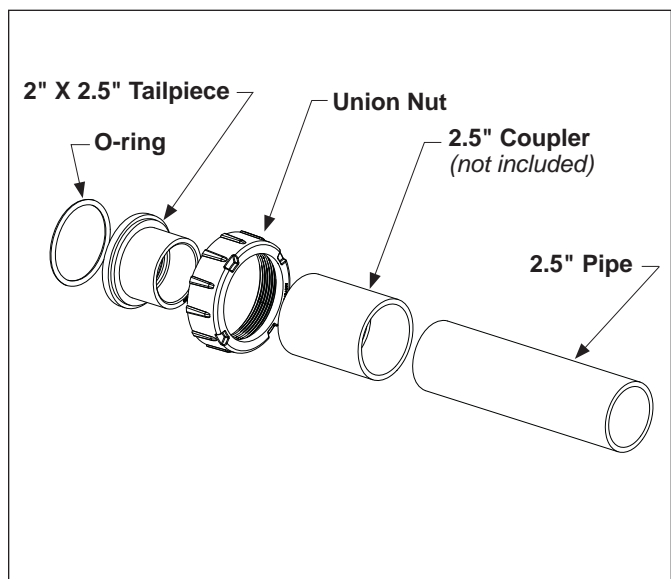

Figure 3. 2" X 2.5" Assembly Shown Connecting a 2.5" Schedule 40 Pipe

3.5 For 2.5" X 3" Tailpiece Replacement Only (Kit R0446102):

- a. For 2.5" pipe size, attach the slip fit side of the tailpiece to the end of the 2.5" pipe as shown in Figure 4.
- b. Allow the glue to cure completely and then continue with step 4.

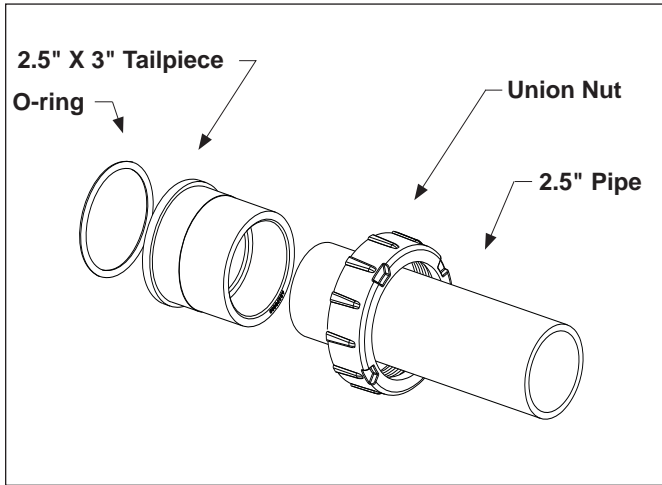

Figure 4. 2.5" X 3" Assembly Shown Connecting a 2.5" Schedule 40 Pipe

- c. For 3" pipe size, attach a 3" coupler (not included in the kit) onto the tailpiece. When gluing the coupler to the tailpiece, do not insert the coupler past the glue line (approximately 1 5/8"). Attach the end of the 3" pipe to the other end of the coupler as shown in Figure 5.
- d. Allow the glue to cure completely and then continue with step 4.

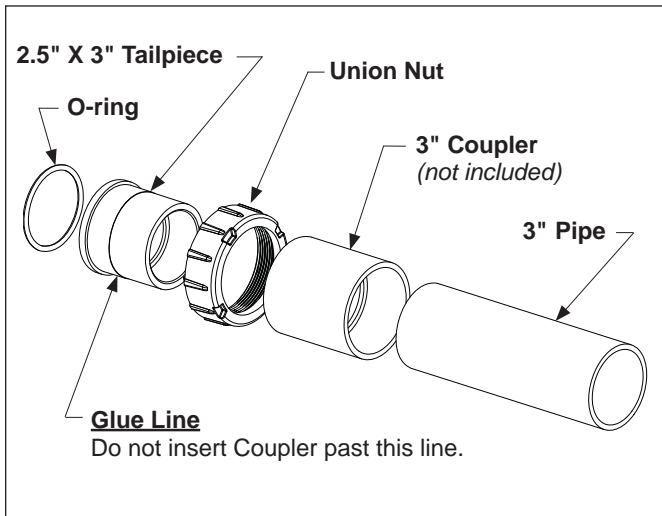

Figure 5. 2.5" X 3" Assembly Shown Connecting a 3" Schedule 40 Pipe

4. Complete Assembly

- 4.1 Before replacing the o-rings, check for debris around the o-rings and mating surfaces. Any debris left in the pump will cause air leaks into the system.

NOTE Great care must be used to keep the o-rings and mating parts clean.

⚠ WARNING

Trapped air in system can cause the filter lid to be blown off which can result in death, serious personal injury, or property damage. Be sure all air is out of system before operating.

- 4.2 Place the new o-ring into the groove of the tailpiece. Hand-tighten the union nuts into the ports of the pump. **Do not use any tools to tighten the union nuts.**
- 4.3 Return valves to proper position for normal operation. Open the filter pressure release valve in order to bleed air.
- 4.4 Once all of the air has been bled from the filter, close the pressure release valve.
- 4.5 Switch on the circuit breaker to the pump motor.
- 4.6 Turn on the pump and check the system for normal operation.

NOTES